

TUFFALOY HIGH PRESSURE WELDING

HIGH PRESSURE TIPS

Spot and projection welding operations may utilize pressures over 2000 lbs. TUFFALOY high-pressure tips have flat bottoms which eliminates tip jamming in tapered holders. Assembled tip and holder heights are always the same, as contrasted to tapered tips which can be forced into the sockets varying distances.

TUFFALOY high pressure tips can be used in the two holder styles shown: PM holders for mounting on the platens of press-type welders, and straight holders for spot welder arm mounting. The tips are held to the holders by a threaded coupling. Copper tungsten faced tips are available for high pressure wear and projection welding.

FLAT FACED

Size 1 PMC-2503
 Part No. 180-2203
 Part No. 180-2203-10W

Size 2 PMC-2104
 Part No. 180-1040
 Part No. 180-2104-10W

TRUNCATED CONE

Size 1 PME-2503
 Part No. 180-2303

| 'A' | Description | Part No. |
|------|-------------|----------|
| 1/4 | PME-21041 | 180-1041 |
| 5/16 | PME-21042 | 180-1042 |
| 3/8 | PME-21043 | 180-1043 |
| 7/16 | PME-21044 | 180-1044 |
| 1/2 | PME-21045 | 180-1045 |

DOME NOSED

Size 1 PMB-2503
 Part No. 180-2103

STRAIGHT HOLDERS CLASS 2 ALLOY

Straight holders are made for carrying TUFFALOY high pressure tips in rocker arm welders or press-type welder horn extensions. They are made in two basic sizes, to accommodate the Size 1 and 2 tips. They are of Class 2 alloy and hold the tips in the same manner as do the PM holders.



| Size | Barrel Dia. | Description | Part No. |
|------|-------------|-------------|----------|
| 1 | 1 | 4511 | 350-4511 |
| 1 | 1-1/4 | 4512 | 350-4512 |
| 1 | 1-1/2 | 4513 | 350-4513 |
| 2 | 1-1/4 | 4521 | 350-4521 |
| 2 | 1-1/2 | 4522 | 350-4522 |



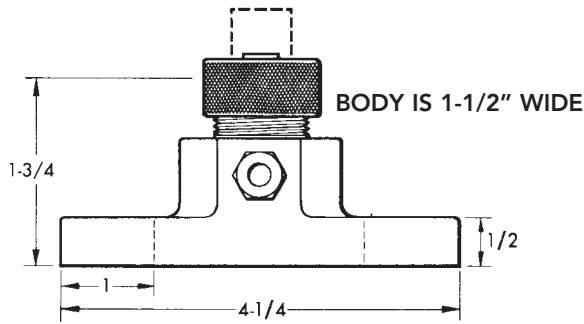

Size 1 PM holder (9/16-in. mounting bolts)
 4510 holder, Part No. 350-4510

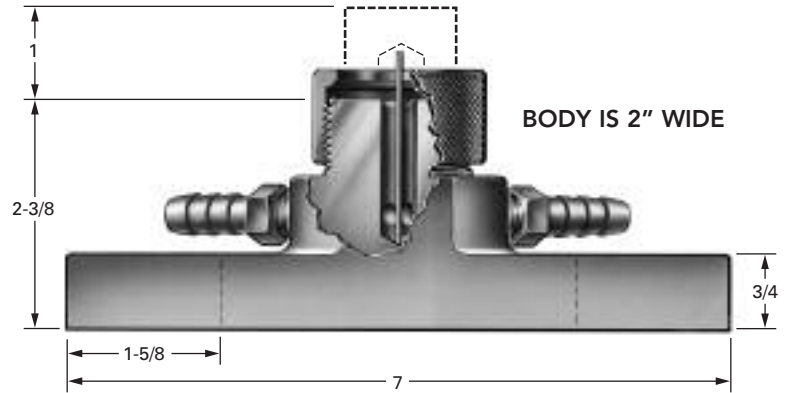

Size 2 PM holder (3/4-in. mounting bolts)
 4520 holder, Part No. 350-4520

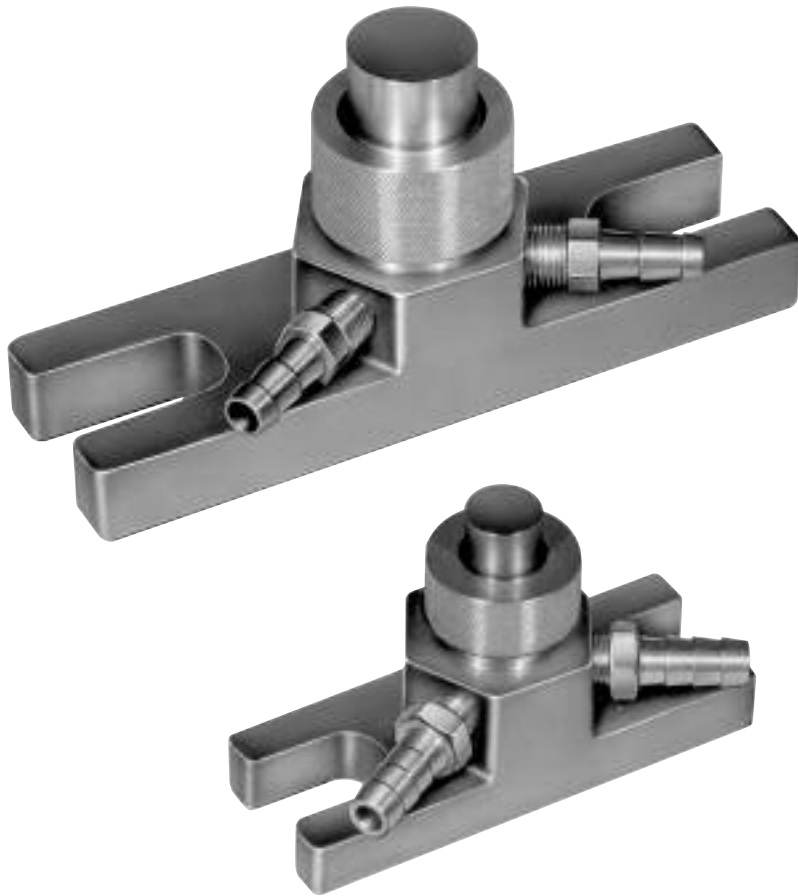

PM HOLDERS

TUFFALOY PM holders are mounted directly to press-type welder platens, or are used as components of special weld fixturing.

Platen Mounting: PM holders bolt easily to the platen T-slots at any desired location, in a minimum of time (no intermediary device is required). Big half-inch mounting bolts may be used to assure good conductivity. They are the first such standard, stocked holders to be made available. They come in two sizes, to match standard T-slot spacing, and to hold the 2 sizes of tips shown. The small size 1 PM holder is for use on RWMA Size 1 press-type welders (3-1/2 in. spacing) and the large size, 2 PM holder is for Size 2 and 3 welders (5- and 6-in. spacing). The electrodes used do not require any particular radial positioning to obtain proper coolant flow. These are compact holders that may be used one-to-one or in multiples in close proximity to one another.

Fixture Building: PM holders make special fixture building easy too. They can be bolted to a fixture or backup base as easily as to a platen. They are compact and have self-contained coolant systems that eliminate making a coolant manifold out of the fixture.

Hose Connections: You may specify where you want the hose connectors in the hexagonal base. Select any two of the six possible locations and specify by using the symbols shown on the diagram (connector locations: A-B, or A-D, etc.). Position A-C is standard. (A-F and C-D are not possible.)

